



SAILING INSTRUCTIONS

**Aberdeen Asset Management 2013/14 Farr 40
Australian Series – One Design Trophy**

Middle Harbour Yacht Club - Sydney, NSW

30 November – 1 December 2013

1. RULES

- 1.1 This Regatta will be governed by:
 - the rules as defined in the 2013-2016 Racing Rules of Sailing (RRS).
 - the rules and regulations of the Farr 40 One Design Class,
 - the prescriptions and special regulations of Yachting Australia
 - the Notice of Race, and these Sailing Instructions.
- 1.2 Boats shall comply with the 2013-2014 Yachting Australia Special Regulations Part 1, Category 7.
- 1.3 Remove the second sentence of RRS 30.2 and replace with the following: "If a boat breaks this rule and is identified, she shall receive, without a hearing, a 10% scoring penalty calculated as stated in rule 44.3 (c)".
- 1.4 Delete the first and second sentences of RRS 44.1 and substitute the following:
A boat may take a One-Turn Penalty, consisting of one tack and one gybe, when she may have broken a rule of Part 2, Rule 31, or Rule 42 while *racing*. However, if a boat may have broken a rule of Part 2 within the zone of a rounding mark or finishing mark, the penalty that may be taken is a Two-Turns Penalty.
- 1.5 The maximum amount of drinkable liquid aboard each boat shall not exceed six (6) litres per person per day. This liquid is included in the restrictions for movable ballast in RRS 51.
- 1.6 Video, and/or photographs taken from any source shall not be used as evidence at protest hearings. This changes RRS 63.6.
- 1.7 Where there is conflict with the Notice of Race, these Sailing Instructions shall prevail. This changes RRS 63.7.

2. NON-COMPETING CLASS REPRESENTATIVE

Jennie Hughes is the Farr 40 Class Administrator.

3. NOTICES TO COMPETITORS

- 3.1 Notices to competitors will be posted on the Official Notice Board located outside the Sailing Office at the Middle Harbour Yacht Club.
- 3.2 The Race Committee may broadcast race information on VHF 72 before and during each race. Failure of such communication to be given or received, or the order in which OCS calls are broadcast, shall not be grounds for redress, except when a request for redress under this instruction is initiated by the Race Committee or Jury. This changes RRS 62.1.

4. CHANGES TO SAILING INSTRUCTIONS

- 4.1 Changes to the schedule will be posted by 2000 AEST on the day before they will take effect and shall be approved by the Class Administrator. Other changes will be posted before 0900hrs on the day they take effect.
- 4.2 Changes to the Sailing Instructions made afloat will be indicated by the display of Code Flag 3rd Substitute accompanied by two sound signals. The change may be communicated either orally or in writing.

5. SIGNALS MADE ASHORE

- 5.1 Signals made ashore will be displayed on the official flagstaff at the Middle Harbour Yacht Club.
- 5.2 The Warning Signal will not be made less than 60 minutes after "AP" is lowered ashore. This changes RRS Race Signals "AP"

6. RACING AREA

- 6.1 The racing area will be on the waters of Sydney Harbour – 'The Sound'.
- 6.2 Boats shall not sail within the area bounded by Cardinal Marks. These areas are prohibited and are deemed to be continuing obstructions.
- 6.3 The attention of skippers is drawn to NSW Roads & Maritime Services regulations regarding the right of way of vessels entering or leaving port and vessels engaged in towing.

SAILING INSTRUCTIONS CONT.

7. SCHEDULE

7.1

Friday - 29.11.2013	1500 – 1700	Registration / Weigh in
	1700	Aberdeen Safety Briefing
	1800	Aberdeen Invitational Race NOTE: Each Farr 40 will be required to take an Aberdeen guest for the race.
Saturday - 30.11.2013	0800 – 0900	Registration / Weigh in
	0830	Skipper/Tactician/PRO briefing
	1100	Racing commences (up to 3 races)
Sunday - 01.12.2013	1100	Racing commences (up to 3 races)
	1600	Trophy presentation.

7.2 The Race Committee may conduct as many races as practical on each scheduled day of racing, up to a maximum of six (6) races for the Series. No Warning Signal will be made after 1500 hours on the last scheduled day of racing.

8. COURSES

8.1 A board displaying the approximate compass bearing to Mark 1, and the course to be sailed will be displayed by the Race Committee Boat prior to the Warning Signal. Note that Start Finish line is in the center of the course in one of the course configurations and constitutes a gate for upwind and downwind legs.

8.2 a) In the event that a Gate is not in place, boats shall round the existing Leeward mark to port.
b) The Gate may be laid after the starting signal.

9. MARKS

9.1 Mark 1, 1a and the Gate marks will be yellow inflatable buoys with Aberdeen Asset Management branding.

9.2 The start / finish mark will be yellow inflatable buoys with Aberdeen Asset Management branding.

10. THE START

10.1 The starting line will be between a staff displaying an orange flag on the Race Committee Signal Boat and the course side of the start/finish mark as described in SI 9.2.

10.2 Class flag for the Farr 40 One Design class will be Code Flag 'F'

11. FINISH

11.1 The finishing line will be between the staff displaying an orange flag on the Race Committee Signal Boat and the course side of the start/finish mark as described in SI 9.2.

11.2 The finishing line may be a shorter length than the starting line.

12. CHANGE OF THE NEXT LEG OF THE COURSE

To change the next leg of the course, the race committee will move the original mark (or finishing line) to a new position per RRS 33.

13. TIME LIMIT

13.1 The time limit for each race shall be 90 minutes.

13.2 Boats failing to finish within 20 minutes after the first boat sails the course and finishes will be scored points for the finishing place equal to the number of boats that finished that race plus 2. This changes RRS 35 and A4.

14. PROTESTS AND REQUESTS FOR REDRESS

14.1 The protest time limit is sixty (60) minutes after the last boat finishes in the last race of that day or the race committee signals no more racing today, whichever is later.

14.2 Notices will be posted within thirty (30) minutes after expiration of the protest time limit to inform competitors of hearings in which they are parties or named as witnesses. Hearings will be held in the jury room.

14.3 The penalty, if any, for any infringement of the rules (including the Class Rules and YA Special Regulations, Category 7) other than RRS Part 2 is at the sole discretion of the Jury in consultation with the Class representative, and may be other than disqualification. This changes RRS 64.1.

14.4 On the last day of the regatta a request for reopening a hearing shall be delivered:
(a) within the protest time limit if the party requesting reopening was informed of the decision on the previous day;
(b) no later than thirty (30) minutes after the party requesting reopening was informed of the decision on that day. This changes RRS 66.

14.5 The Protest time limit for sailor classification is 60 minutes after the last boat finishes in the last race of Day 1.

SAILING INSTRUCTIONS CONT.

15. FLAGS AND DECALS ON BOATS

15.1 Materials may be provided to each boat at registration. If provided, signage should be displayed from no later than the close of Registration on Friday 29 November, 2013 until 1600 hours on Sunday, 1 December 2013.

16. **REGISTRATION** - Refer to Notice of Race 5.4

17. **MEASUREMENT** - Refer to Notice of Race 7

18. **SCORING** - Refer to Notice of Race 12

19. **PRIZES** - Refer to Notice of Race 13

20. **SUPPORT BOATS** - Refer to Notice of Race 15

21. **HAUL-OUT RESTRICTIONS** - Refer to Notice of Race 16

22. **DISCLAIMER OF LIABILITY** - Refer to Notice of Race 20

ATTACHMENT 1: COURSE

Code	Course
2	Start - 1 - 1a - start/finish - 2s/p - Finish (upwind)
3	Start - 1 - 1a - start/finish - 2s/p - start/finish - 1 - 1a - Finish (downwind)
4	Start - 1 - 1a - start/finish - 2s/p - start/finish - 1 - 1a - start/finish - 2s/p - Finish (upwind)
5	Start - 1 - 1a - start/finish - 2s/p - start/finish - 1 - 1a - start/finish - 2s/p - start/finish - 1 - 1a - Finish (upwind)
W2	Start - 1 - 1a - 2s/p - 1 - 1a - Finish
W3	Start - 1 - 1a - 2s/p - 1 - 1a - 2s/p - 1 - 1a - Finish

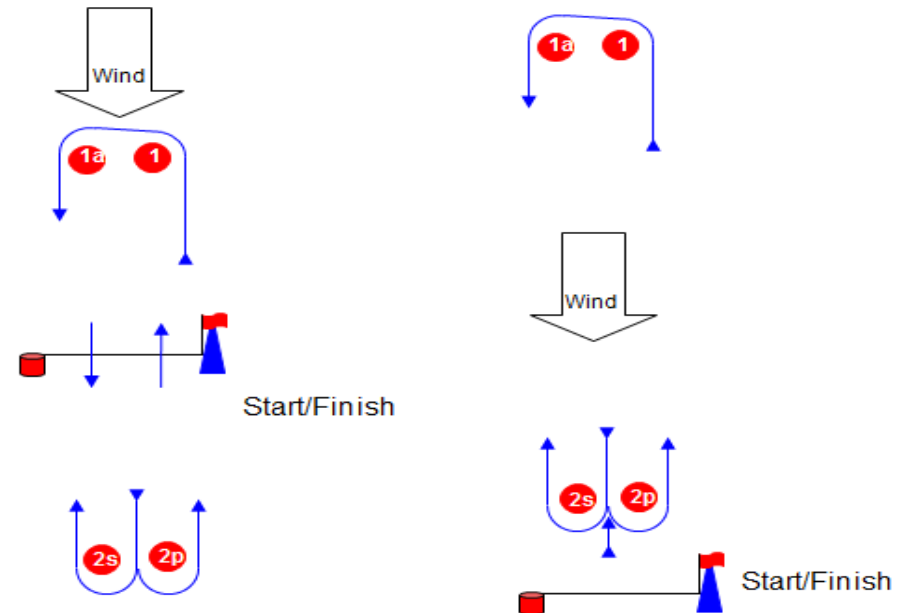

ATTACHMENT 2: COURSE CHARTLET

